

Sealed lead acid batteries

40 Ah mainship battery



Securaplane Sealed Lead Acid (SLA) mainship batteries have technology that beats NiCad, lead-calcium and lead antimony in every category of performance, ultimately saving operators thousands of dollars annually.

Securaplane is the master distributor and design and certification authority for EnerSys Hawker brand batteries for commercial and business aviation in the USA.

Hawker mainship batteries offer significant performance enhancements compared to competing products.

Key features

- 99.99% pure lead construction for enhanced life and performance.
- Batteries shipped fully charged and ready to install.
- Non-hazardous for shipping by ground and air.
- True no-maintenance with unsurpassed cranking power.
- Hot and cold performance exceeds competing products.
- Monobloc replacement significantly less than the list price of new battery.

Applications

Securaplane 40 Ah batteries are STC- and PMA-approved for installation on numerous aircraft, including:

- ATR 42/72
- Caravan 208, 208B
- Challenger 600, 601
- Gulfstream GII/GIII (DC)
- Mitsubishi MU-2B-36, -36A, -60

Securaplane

Our product competencies and services

Aircraft security systems | Airborne video cameras | Aircraft batteries | Battery chargers | Inverters | Converters | Wireless integration

Sealed lead-acid batteries

40 Ah mainship battery

Specifications

Part number
9750W0538

Size
11.05 x 11.97 x 10.35 inches max

DC connector (J1)
MS18093/MS3509

Temperature sensor connector (J2)
Per application requirements

Qualification
DO-160C

Weight
83.8 lb (38 kg)

Nominal voltage
24V

Nominal capacity
40Ah

Transportation
Non-hazardous and unrestricted when securely packed and protected against short circuit.

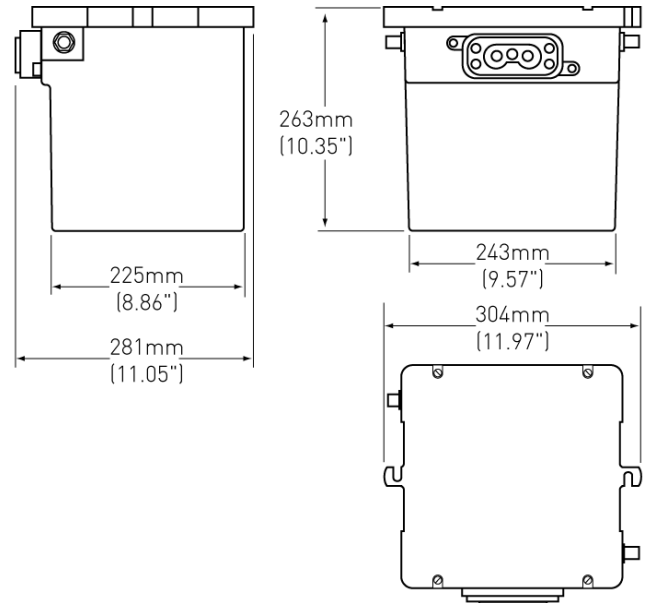

Specification subject to change.
Images for illustration only.
Please contact Securaplane for installation data

Performance

Storage of uncommissioned product

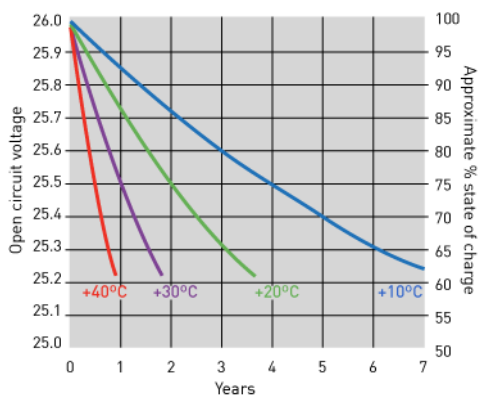

Charge recovery rate vs charge voltage

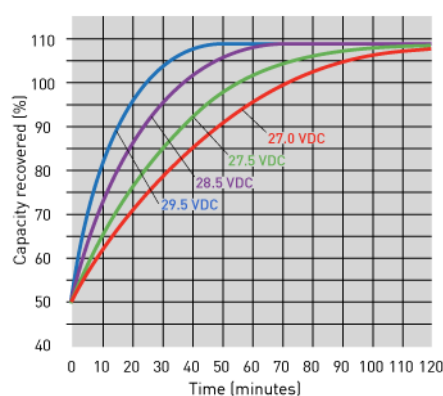

Power rating

Testing of Group B sample to Batspec 210 clause of 3.9 and IEC 952-1 clause 6
Test Reference PDTR 1817 - June 1998

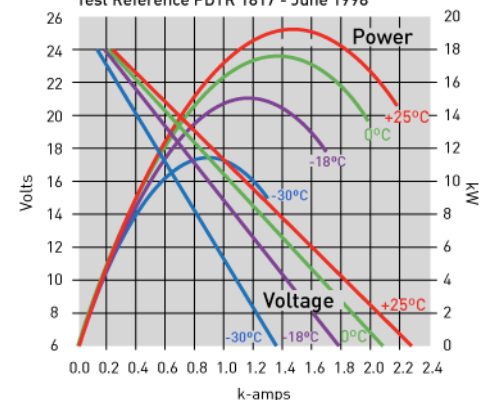

Securaplane

12350 N Vistoso Park Road
Oro Valley AZ 85755
USA

Tel: +1 (520) 297 0844
Fax: +1 (520) 498 4924

www.securaplane.com
www.meggitt.com

MEGGITT
smart engineering for
extreme environments